



POWELL HALL TECHNICAL SPECIFICATIONS
AND BUILDING INFORMATION
Information current as of 2/21/2019

Mailing/Physical Address

718 N Grand Blvd
St. Louis, MO 63103

Staff Contact

Maggie Bailey
Director of Operations
314-286-4123 (o)
314-544-7023 (f)
maggieb@slo.org

Hall Capacity

Orchestra level	1262
Grand Tier	158
Balcony	1217
Accessible seats	28
Total	2665

Stage

Type: Proscenium, permanent acoustic shell, no curtains or drapes, no rigging capabilities.

Access: Two (2) double side doors, 70" wide x 83" high, downstage at proscenium line. There are two (2) elevated doors on stage right and stage left at the upstage wall, 34" wide x 78" high and 3' above stage floor.
There is a crossover hallway behind the stage.

Dimensions: 66' 7" wide x 42' 11" high
Shell Ceiling slopes from 42'-11" high at proscenium to 25'-1" at US wall
Depth (apron to back wall center) 41' 1"
Proscenium line to back wall 32'
Offstage (proscenium to side wall) right 12', left 9'
Proscenium to edge of apron (center) 9' 1" Proscenium opening 66' 7"
(See stage diagrams at end)

Stage Floor

Tongue and groove. Lagging to floor is not permitted anywhere. No traps.
Orchestra Lift: to storage area below the stage. Lift measures 8' 11" deep x 13' 11" wide, DS edge of lift: 45" upstage of edge of stage, equidistant SR & SL of centerline. Lift not for use during productions.

Stage Lighting

Lighting is repertory for orchestral presentation being designed to evenly illuminate entire stage area in white light and allow for minimal zonal control. See attached Repertory Lighting Plot.

Control: ETC Ion 2000 lighting control for stage and auditorium lighting

Accessories:

1x20 Universal Fader module
2 @ flat screen monitor
Alphanumeric keyboard
USB Mouse
Gooseneck lamp

1 @ 15 channel/9 preset Snapshot Architectural lighting controller backstage right.
1 @ 15 channel/9 preset lighting Snapshot in booth (FOH).

The Ion 2000 mainly lives backstage right but can be relocated to the mix position at the Orchestra level rear center (68' from DS edge of Stage).

Dimming: 2 @ 24 module Sensor installation racks
4 @ D50AF, 20 @ D20 modules per rack
1 @ 6 channel remote dimmers (10A each circuit @ HR Balcony Boom 1), Edison 520R
6 @ Elation UniBar remote dimmer (10A each circuit @ HL Balcony Boom 1), Edison 520R
4 @ Elation UniBar remote dimmer for S4 ERS (10A each circuit @ SR & SL Torms), Edison 520R
2 @ Elation UniBar remote dimmer spares (10A each circuit), Edison 520R

Stage Lighting Distribution: Cove position: 7 @ dimmer/circuits, 20A, Twistlock pin out (GTL)
Torm SR: 5 @ dimmer/circuits, 20A, Twistlock pin out (GTL)
Torm SL: 5 @ dimmer/circuits, 20A, Twistlock pin out (GTL)
Shell: 13 @ dimmer/circuits, 20A, Twistlock pin out (GTL)

All other rack dimmers are for permanent house lighting only.

Networking: Two universes (1 & 2) are available at the console via 5-pin XLR.

Stage right control Area:

Universe 1

Elation DMX Branch x4 booster. 4-way DMX distributor, 1 x DMX Input, 4 x DMX outputs &

1 DMX thru

Electronic & Opto isolated

3 & 5 pin XLR DMX connectors

1. House racks
2. Balcony booms to Elation DMX Branch x4 booster. 4-way DMX distributor, 1 x DMX Input, 4 x DMX outputs & 1 DMX thru for control to 4 @ Balcony booms (Located HL Cove position)
3. Stage Light crossovers
4. Open

Wall Station to House racks:

DMX 1 & 2 input

RFU

ETCLink

DMX 2 output

2 @ 5 pin XLR DMX runs to FOH mix position

1 @ CAT 5 Ethernet run to FOH mix position

Lighting Fixtures: FOH Cove (27' 6" Downstage of edge of stage, 84' above stage floor (A.S.F.). Isolated from Auditorium through tempered glass.)

10° SPCL, CH. 30
 10° SPCL, CH. 35
 10° SPCL, CH. 37
 VN WASH 1, CH. 32
 VN WASH 2, CH. 33
 VN WASH 3, CH. 34
 5° SPCL, CH. 38
 VN WASH 1, CH. 32
 VN WASH 2, CH. 33
 VN WASH 3, CH. 34
 10° COND (TWO-FER), CH. 1
 10° COND (TWO-FER), CH. 1
 VN WASH 1, CH. 32
 VN WASH 2, CH. 33
 VN WASH 3, CH. 34
 5° SPCL, CH. 39
 VN WASH 1, CH. 32
 VN WASH 2, CH. 33
 VN WASH 3, CH. 34
 10° SPCL, CH. 37
 10° SPCL, CH. 36
 10° SPCL, CH. 31

HR & HL lower balcony ladder rails (two 6' wide rails, approx. 23' & 25' A.S.F., 82' from down stage center edge of stage)

<u>Top pipe</u>	<u>Bottom pipe</u>
10° F/L COND, HR 2, HL 3	14° WASH NEAR, HR 10, HL 11
10° F/L SOLOIST, HR 4, HL 5	14° WASH CTR, HR 8, HL 9
<u>10° F/L FAR, HR 6, HL 7</u>	14° WASH CTR, HR 28, HL 29

HR & HL upper balcony ladder rails (two 6' wide rails, approx., 33' & 35' A.S.F., 102' from down stage center edge of stage)

<u>Each Ladder:</u>	<u>ONSTAGE</u>
<u>OFFSTAGE</u>	No house fixtures
No house fixtures	

SR & SL on stage Torms (upstage of Proscenium line, 10' 10" A.S.F. to top of proscenium arch), 15'7" US of DS edge of stage

Each torm:
 MFL WASH 1, SR 40, SL 41
 MFL WASH 2, SR 42, SL 43
 MFL WASH 3, SR 44, SL 45
 MFL WASH 1, SR 40, SL 41
 MFL WASH 2, SR 42, SL 43
 MFL WASH 3, SR 44, SL 45
 19° SPCL, SR 114, SL 112
 26° SPCL, SR 117, SL 116
 NSP CHORUS FAR, SR 12, SL 13
 MFL CHORUS MID, SR 12, SL 13

WFL CHORUS NEAR, SR 12, SL 13
WFL WASH 4, SR 46, SL 47
WFL WASH 4, SR 46, SL 47
WFL WASH 4, SR 46, SL 47

Shell: (overhead lighting strips built into shell, No color ONLY)
26 @ L&E PAR 20 9-Light Strip – 675W per strip

Spares:
2 @ Source 4 19° ERS – 575W (currently hung on SR & SL torm)
2 @ Source 4 26° ERS – 575W (currently hung on SR & SL torm)
2 @ PAR56 MFL – 500W (chrome)

Booth: Spotlights:
2 @ Xenon Super Troupers. 1.6K
Spot throw from booth to apron approx. 170'

Additional Equipment:
2 @ Source 4 pattern holders
2 @ floor bases
4 @ 6" barndoors
4 @ 10" barndoors
Assorted turnarounds (GTL, Twistlock L520, Edison 520)

Electrical

Sound Power: 1 @ 120/240 volts (single phase), 100A

Company Switch: 1 @ 240 volts (3 phase), 200A – 16 series cam-locks located off stage left

Booth: Spots:
2 @ 30A 209VAC 3 Phase, L6-30 receptacles

Projection:
1 @ 30 amp (3 phase), lugs
1 @ 100 amp (3 phase), lugs

General:
6 @ 20A/120V

Video

Located in Booth

Projector: 2 Barco HDX W18 18K Lumen HD Projectors
1920 x 1080P60 via 3G HD-SDI or 1920 x 1200 via DVI-D

170' throw to 18' x 24' retractable DaLite perforated screen.

Projection Screens: Permanent retraceable perforated screen located at 35' 10" upstage of edge of stage.
 Low trim is 9' 4" above the stage floor, however, with recording microphones installed, the lowest trim available is usually 11'.

(3) Draper Truss Stage Screens with black backed XT1000VB surface. Truss screen is hung 16' from down stage center lip of stage.

- 18' x 32' (16:9)
- 13.6' x 32' (2.35:1)
- 24' x 18' (4:3)

Monitor: 2 Ikegami ULE 217 21 inch HD Monitors
 Low latency 1920 x 1080P60 broadcast monitor, w/3G HD-SDI, HDMI, composite, VGA inputs
 1 Lilliput RM-1703 17.3" Rackmount Monitor

Switcher: 1 Blackmagic Design ATEM 1 M/E Production Studio 4K

Recording/Playback: 1 Blackmagic Design HyperDeck Studio Mini

Source Accessories:

Quant.	Make	Model	Notes	Further Notes
2	Tascam	DV DO-1U	DVD player	HDMI, component, S-Video, Composite outputs
1	Tascam	BD-01u	Blu-ray player	HDMI
4	AJA	HA5 Plus	HDMI to 3G HD-SDI converter	up to 1920 X 1080P60
2	AJA	HI5 Plus	3G HD-SDI to HDMI converter	up to 1920 X 1080P60 Transmits 3G full HD (1920 X 1080P60) single mode fiber with
4	AJA	FiDO-T-ST	SDI to Fiber Optical converter	ST connectors Receives 3G full HD (1920 X 1080P60) single mode fiber with
4	AJA	FiDO-R-ST	Fiber to SDI Optical converter	ST connectors

Cables:

Quant.	End	End	Length	Type	Further Notes
4	DVI	HDMI	10	Video	Adaptor
6	HDMI	HDMI	3	Video	Jumper
1	DVI-D	Mini Display		Video	Adaptor
1	DVI-I	Port		Video	Adaptor

		Display Port Mini Display Port		Video	Convertor
1	VGA				
4	ST	ST	2 m	Fiber Jumper	Duplex, Yellow
4	ST	ST	10 m	Fiber Jumper	Duplex, Yellow
				4 X Fiber line sub snake	
1	ST	ST	125ft	6 X Fiber Line installed	Single Mode Fiber; for temporary runs on Stage
1	ST	ST	280ft	6 X Fiber Line installed	Single Mode Fiber; Stage Right to Projection Booth
1	ST	ST	180ft		Single Mode Fiber; Stage Right to Front of House Location
3	SDI	SDI	280ft	3G HD-SDI installed	RG6 4.5 Ghz Coax; Stage Right to Projection Booth
1	SDI	SDI	180ft	3G HD-SDI installed	RG6 4.5 Ghz Coax; Stage Right to Front of House Location
1	SDI	SDI	100ft	3G HD-SDI	RG6 4.5 Ghz coax; for temporary runs on Stage
2	SDI	SDI	60ft	3G HD-SDI	RG6 4.5 Ghz Coax; Control booth to Projection Booth
1	SDI	SDI	10ft	3G HD-SDI	RG6 Jumpers
2	SDI	SDI	6ft	3G HD-SDI	RG6 Jumpers
2	SDI	SDI	3	3G HD-SDI	RG6 Jumpers
5	SDI	SDI	1.5ft	3G HD-SDI	RG6 Jumpers
				Cat 6 data lines installed	
4	Cat6	Cat6	280ft		Stage Right to Projection Booth
				Cat 6 data lines installed	
2	Cat6	Cat6	180ft		Stage Right to Front of House Location
				Cat 6 data lines installed	
4	Cat6	Cat6	160ft		Projection Booth to Amp Room/Library entrances on Balcony

Sound

FOH Console: Yamaha CL5
64 channels Yamaha Remote Stage Box

Mix Position: Center of house floor. 7' wide x 11' deep workable area 68' from stage.
Two 20 amp circuits

House system: House Left and Right: Danley J3-94-b with DNA20k4 amps
Upper Balcony: 2 Danley SH621-b with DNA10k8 amps
Front fill: 5 Danley Nano loudspeaker with LabGruppen amp
Optional onstage Subwoofer: 2 Danley TH118T-B with DNA10k8 amp

Monitor Console: Yamaha QL5
8 permanent monitor amp channels

8 additional amp channels in stage rack

Monitors: Stage Side fill: 2 Danley SBH20s
2 Powered Hotspots
6 Danley SM100M wedges
2 Danley SHMicro wedges
15 user Aviom monitor mix system
4 P3T Shure transmitters
8 Shure P3RA receivers
4 P9T Shure transmitters
4 Shure P9RA receivers

Microphones: 50 Countryman B3 Contact Mics
8 Shure KSM137
2 Shure KSM 141
4 Shure KSM8
10 Shure SM58
6 Shure SM57
1 Shure Beta52
5 Sennhieser E604
2 Shure Beta87a
2 Shure Beta57a
1 Shure Beta58
4 Neumann KM184
2 Neumann TLM102
1 DPA VO4099CM with Harp Mount
2 DPA VO4099P Piano Mount system
6 DPA VO4099B
2 DPA 4088 Headset

Intercom: Clear- Com. power supply backstage right
10 belt packs and single muff headsets
2 telephone handsets
Wired intercom positions offstage right and left, spot booth, FOH, SM office

Additional: Listen LT800 Assistive Listening System
32 Portable display FM receiver
32 LA-165 Stereo headphones
10 LA-166 Inductive neck loop
Numark dual CD player
Backstage paging system

Backline

The Symphony owns three (3) Steinway 9ft concert grand pianos tuned to A=442. All other backline to be provided by outside vendors.

Tuning

The St. Louis Symphony tunes to A=442.

Dressing Rooms

- Stage level: Green Room (30' x 16') - used as production office.
Grand piano
Furnished with couch, chair and ottoman, 2 arm chairs, refrigerator
Telephone with outside access and wired/wireless internet
Adjoining restroom with single shower
- Second floor: Soloist dressing room (12' x 9')
Furnished with chair, sink/vanity, and upright piano
Wireless internet access
Restroom with single shower
- Seventh floor: Two conference rooms available for use as dressing rooms (11' x 20' and 13' x 9').
Restrooms located on same floor, but not adjoining. No shower facilities on floor.

Other spaces to be made available as necessary.

Catering - Whitaker Room

Room Space- ample space for seating up to 32 at one time (4/rounds with 8 chairs at each).
Men's and Ladies' restrooms available (no shower).
No kitchen- appliances, oven, sink, etc.

Loading

NO TRUCK DOCK. NO FORKLIFT. LIFT GATE STRONGLY RECOMMENDED!

Loading doors are at stage level and street level. Loading area in alley directly south of building can accommodate a 45' van side load; no straight in egress from alley; truck must back in to alley. Entrance to the loading area is just east of the venue through a chained entrance.

There are two sets of doors, 6'x7', between loading dock and stage. The outermost, exterior double door opening is 94" wide x 105" high. There is a slight ramp up to the interior set of double doors. The door opening is 83" wide x 100" high.

There are no steps to stage area from loading areas. The stage door is located on the north side of the building on Delmar Boulevard.

Parking - Support Vehicles

The Symphony does not own or operate any parking lots or structures. On-street parking adjacent to Powell Hall must be reserved in advance for all tour buses, trucks, vans, limousines, and any other support vehicles. Trucks must vacate the alley between load-in and load-out. No exterior utility sources are available (no bus power or water).

Security

Powell Hall employs a security officer at the stage door entrance to control access and monitor its closed-circuit cameras any time the building is occupied. Additional officers are hired during rehearsals and events as needed to patrol the building exterior and public parking locations. For a typical full-house performance, 6 courtesy patrol officers are scheduled for 4-hour minimum shifts to span the time before doors open to the public and the last employee departs. Rehearsals are covered as needed based on the day and time as well as the number of participants.

Box Office/Ticketing

The St. Louis Symphony Orchestra box office is located in Powell Hall. The box office is fully run and managed in-house using the Tessitura ticketing system.

Powell Hall is a union house.

Powell Hall is a smoke-free facility. Guests are requested to smoke outside the building.

Deliveries should be scheduled in advance.

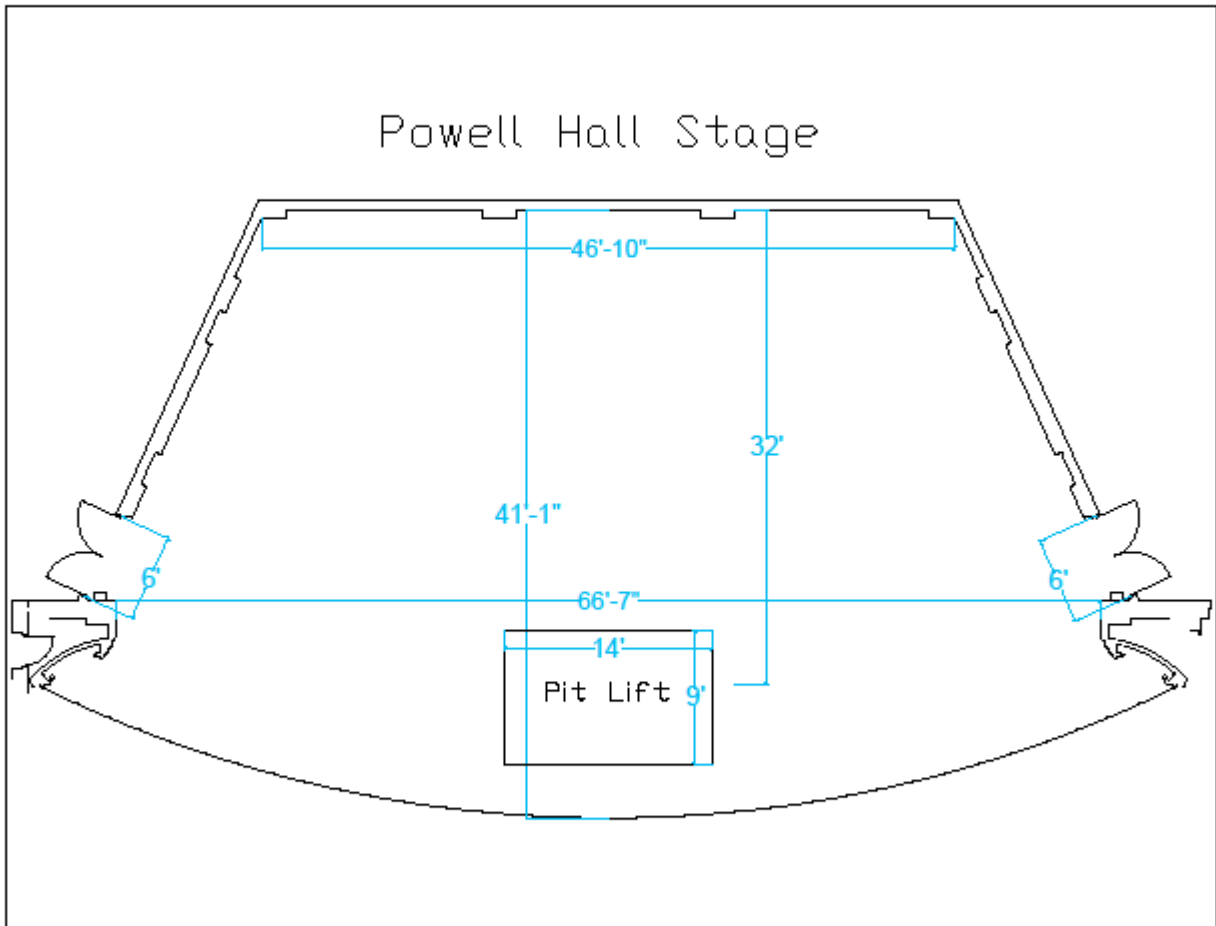
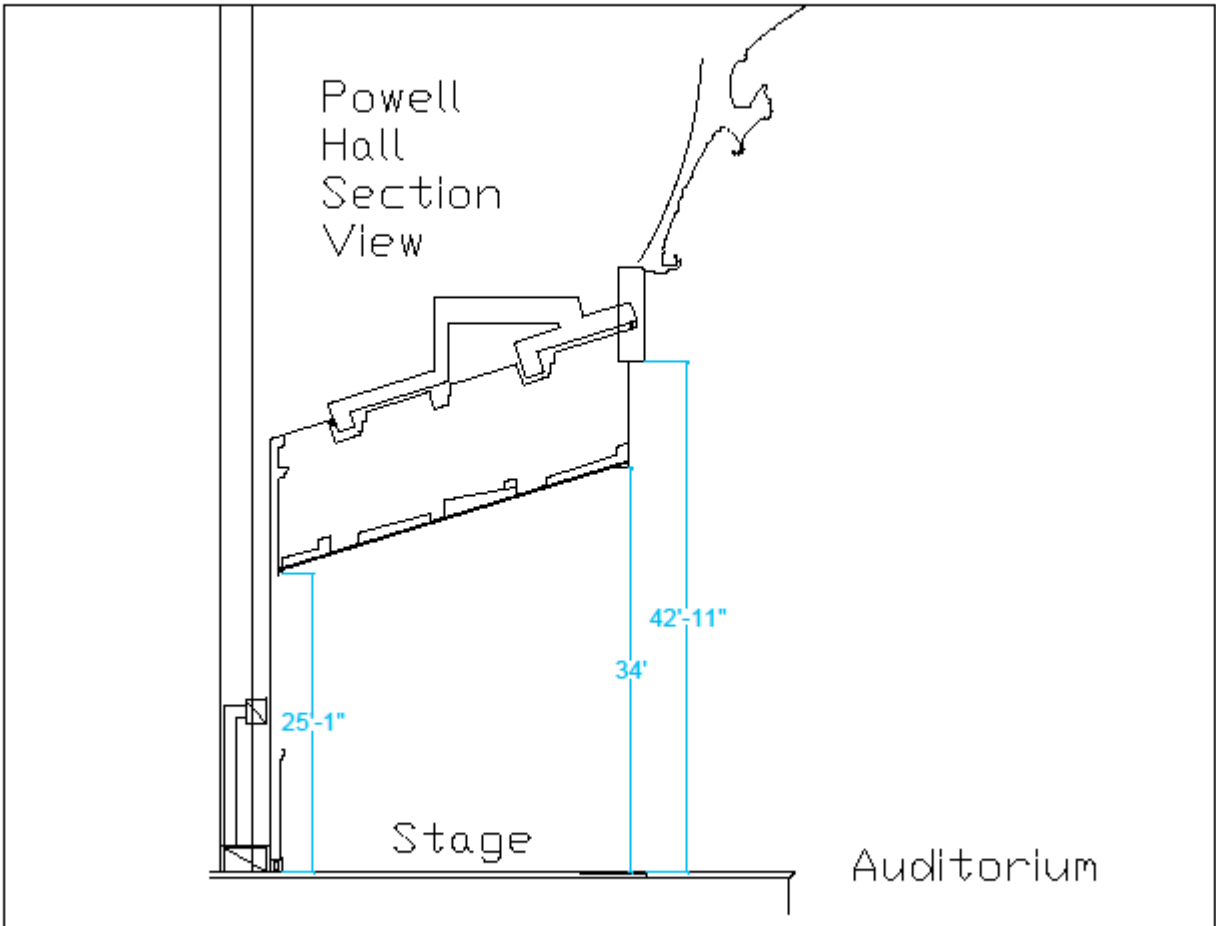

Directions from Lambert-St Louis International Airport to Powell Hall:

Merge onto I-70 East towards St. Louis. Exit I-70 East at Grand Boulevard, turn South on Grand. Powell Hall is on the Left, East, side of the street approximately 3 miles South. Parking is accessible off of Delmar Boulevard on the North or by Samuel Shepard Drive on the South side of the building. Approximate travel time for airport to hall- 25 minutes.

